

NPT Active 2 Door Digital Refrigerator, 1430lt (-2/+10) - Remote

ITEM # _____

MODEL # _____

NAME # _____

SIS # _____

AIA # _____



110131 (NPT142FRR)

2-door refrigerator
1430lt, -2/+10°C, digital,
remote, AISI 304

Short Form Specification

Item No.

Two full door refrigerator entirely constructed in 304 AISI stainless steel with bottom panel in anti-corrosive material. Large digital white-digit display with cabinet temperature display and setting, and possibility to select the desired levels of humidity. HACCP-compliant control with alarms and history. Automatic defrost activates only when required with automatic evaporation of defrost water. Optimized back to front forced air flow and removable air conveyors provide even temperature distribution and fast cooling in any conditions. Fitted with 75 mm-thick cyclopentane insulating foam. Door features lock and door microswitch to switch off the fan when the door is opened. Hidden evaporator to guarantee higher storage capacity and less corrosion problems. Remote refrigeration unit; ventilated operation; Internal LED light and internal back light. Supplied with n. 8x2/1GN Rilsan coated grids and n. 8 sets of 2 stainless steel grid runners. Prearranged to fit RS485 port to facilitate connection to a remote computer and integrated HACCP systems.

Main Features

- Large storage area suitable to contain 2/1 GN grids or shelves on anti-tilt runners.
- Operating temperature can be adjusted from -2 to +10 °C to suit different food storage requirements.
- Cabinet fitted with up to 75 mm thickness of cyclopentane insulation for best insulating performance with 100% environmental protection (thermal conductivity: 0,020 W/m*K).
- 60 mm-thick insulation covering the evaporator can be easily removed with a single operation.
- The Active Defrost activates the defrost cycle only when necessary and only for the required time.
- Back to front forced air flow and removable air conveyors provide even temperature distribution and fast cooling in any conditions.
- Optiflow: back to front forced air flow and removable air conveyors provide even temperature distribution and fast cooling in any conditions.
- Performance guaranteed at ambient temperatures of +40°C (Climatic class 5).
- Internal structure with 44 charging positions available to host grids, ensuring higher net capacity and a greater storage space.
- Possibility to select 3 different levels of humidity according with the type of food stored inside.
- Prearranged to fit RS485 port to facilitate connection to a remote computer and integrated HACCP systems.
- Tropicalized unit.

Construction

- Constructed from the highest quality AISI 304 Stainless steel.
- Interior base with rounded corners, pressed from a single sheet.
- The rounded internal corners, the easily removable runners, grids and air conveyors allow for ease of cleaning and high hygiene standards.
- Stainless steel runners and supports easily disassembled.
- Anti-corrosion bottom material avoids any damage that may be caused to the cabinet by aggressive detergents employed to clean the floors.
- Easy access to the main components for maintenance.
- Lockable door.
- Refrigerant type: R134a.
- Remote refrigeration unit.

User Interface & Data Management

- Zanussi Professional Fridge Control APP makes the life easier for our customers:
 - Monitor safety of preservation process thanks to HACCP data & alarms for precise control
 - Save time and easy data management having the possibility to send the HACCP information in excel format directly to e-mail address

APPROVAL: _____

- Quick operations: set the cabinet temperature/humidity/turbocooling and set date/hour
- Large digital white-digit display with cabinet temperature display and setting, and possibility to select the desired levels of humidity. Bluetooth technology included allows to keep HACCP historical data and download them through the app.
- Large digital white-digit display with cabinet temperature display and setting, activation of turbo frost cycle (to rapidly cool warm loads) and possibility to activate manually the defrost cycle.

Sustainability

- Automatic evaporation of the defrosting water by hot gas on the top for energy saving.
- Cleaning-free condenser: the structure of the wire frame condenser prevents dust and grease accumulation thus avoiding periodical cleaning operations and reducing energy consumption.
- Frost Watch Control: fully automatic defrost starts only when ice is actually building-up in the evaporator and adapt the defrosting duration to guarantee perfect ice removal while optimizing energy efficiency consumption.
- CFC and HCFC free, highly ecological refrigerant type: R290 (ecological gas in foam: cyclopentane). Hydrocarbon refrigerant gas R290 for the lowest environmental impact (GWP=3), to reduce green house and ozone depletion effects.
- Cabinet certified as Class A in heavy duty working conditions (40°C-40% humidity) based on European Ecodesign directive.
- The label complies with the delegated regulation (UE) 2015/1094 of the commission of 5th may 2015.
- CFC and HCFC-free insulation.
- Interior LED light to save energy and for best internal visibility.
- Door switch stops the fan when door is opened to avoid cold air exiting the cell, thus saving energy.
- Removable triple-chamber balloon magnetic gasket to improve insulation and reduce energy consumption and ease of cleaning.
- Improved defrost and evaporator fan management – defrost type changes with temperature set-point: electric below +2° C while air convection defrost above +2°C, thus saving energy.

- | | | |
|--|------------|--------------------------|
| • Meat rail for 670/1430lt refrigerators with 4 hooks | PNC 881019 | <input type="checkbox"/> |
| • 2/1GN grey rilsan grid with 2 runners | PNC 881020 | <input type="checkbox"/> |
| • Set of 2 stainless steel runners for 670/1430lt refrigerators and freezers | PNC 881021 | <input type="checkbox"/> |
| • Pedal opening for 1430lt refrigerator | PNC 881033 | <input type="checkbox"/> |
| • 2/1GN pvc container with lid and 2 runners | PNC 881039 | <input type="checkbox"/> |
| • 2/1GN perforated shelf | PNC 881042 | <input type="checkbox"/> |
| • 1/1GN rilsan steel wire basket h=150mm | PNC 881043 | <input type="checkbox"/> |
| • 3 grey rilsan central grids for 1430lt (not for glass door) | PNC 881044 | <input type="checkbox"/> |
| • 2/1GN grey rilsan basket+2 runners h=150mm | PNC 881047 | <input type="checkbox"/> |
| • 5 swivelling wheels (2 with brake), diam 125mm, for 1430 lt refrigerators, NOT for remote models | PNC 881294 | <input type="checkbox"/> |
| • IoT module for refrigerated cabinets and counters | PNC 881298 | <input type="checkbox"/> |

Included Accessories

- 8 of 2/1GN grey rilsan grid with 2 runners PNC 881020

Optional Accessories

- | | | |
|--|------------|--------------------------|
| • Remote unit -2+10°C for 1430lt refrigerated cabinets | PNC 880232 | <input type="checkbox"/> |
| • 2 stainless steel runners for refrigerated cabinets (Marine) | PNC 880242 | <input type="checkbox"/> |
| • Set of 8 GN1/1 PVC containers for fish | PNC 880243 | <input type="checkbox"/> |
| • Spacer for 670 lt and 1430 lt refrigerated cabinets | PNC 880248 | <input type="checkbox"/> |
| • Kit to fit 20 pastry trays (400x600mm) | PNC 880333 | <input type="checkbox"/> |
| • 1/1GN plastic container with false bottom | PNC 880705 | <input type="checkbox"/> |
| • 2/1GN grey rilsan grid | PNC 881004 | <input type="checkbox"/> |
| • 2/1GN aisi 304 stainless steel grid | PNC 881016 | <input type="checkbox"/> |
| • 2/1GN 304 AISI stainless steel grid with 2 runners | PNC 881018 | <input type="checkbox"/> |

Front

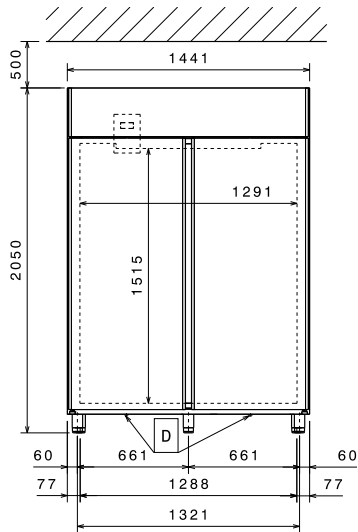

Side

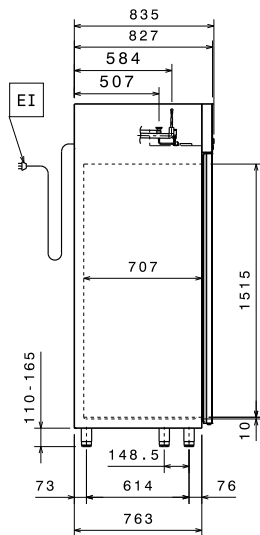

EI = Electrical inlet (power)
RI = Refrigerant Inlet
RO = Refrigerant Outlet

Top

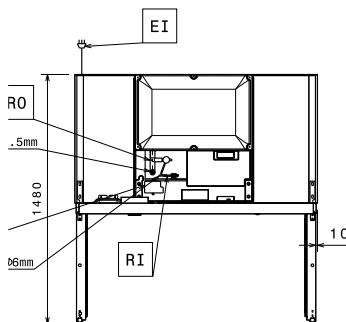

Electric

Supply voltage: 220-240 V/1 ph/50/60 Hz
Electrical power, max: 0.16 kW

Capacity:

Number and type of grids (included): 8 - GN 2/1

Key Information:

Door hinges:
External dimensions, Width: 1441 mm
External dimensions, Depth: 835 mm
External dimensions, Depth with Doors Open: 1480 mm
External dimensions, Height: 2050 mm
Number and type of doors: 2 Full
Type of external material: 304 AISI
Type of internal material: 304 AISI
Internal panels material: 304 AISI
Number of positions & pitch: 44; 30 mm
Gross capacity: 1430 lt

Refrigeration Data

Control type: Digital
Refrigeration type: R134a;R513A;R426A
Suggested refrigeration power: 458 W
Condition at evaporation temperature: -10 °C
Condition at condensation temperature: 55 °C
Condition at ambient temperature: 43 °C
Connection pipes (remote) - outlet: 9.5 mm
Connection pipes (remote) - inlet: 6 mm

***Note:**

Ref. Power calculated at a linear distance of 15 mt (piping)